

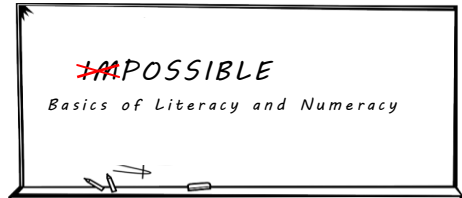

Erasmus+



The project is funded by the European Commission

Bingo game

The game is similar to any variations of bingo game. But instead of telling number, the teacher tells the students formulas of different geometric shapes and the students have to find the adequate shape on their chart.

You also can play this game with:

- literature: writers – titles, quotations – writers etc.
- history: dates – events, personality – events etc.
- foreign languages: words – pictures, infinitive – past form etc.
- etc.



Erasmus+

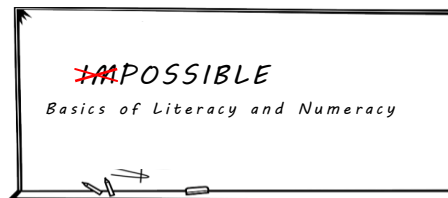

The project is funded by the European Commission

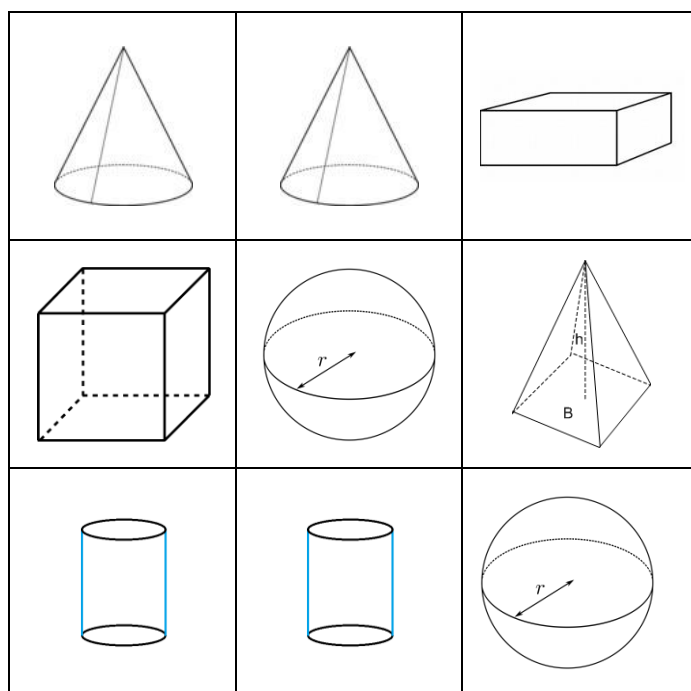
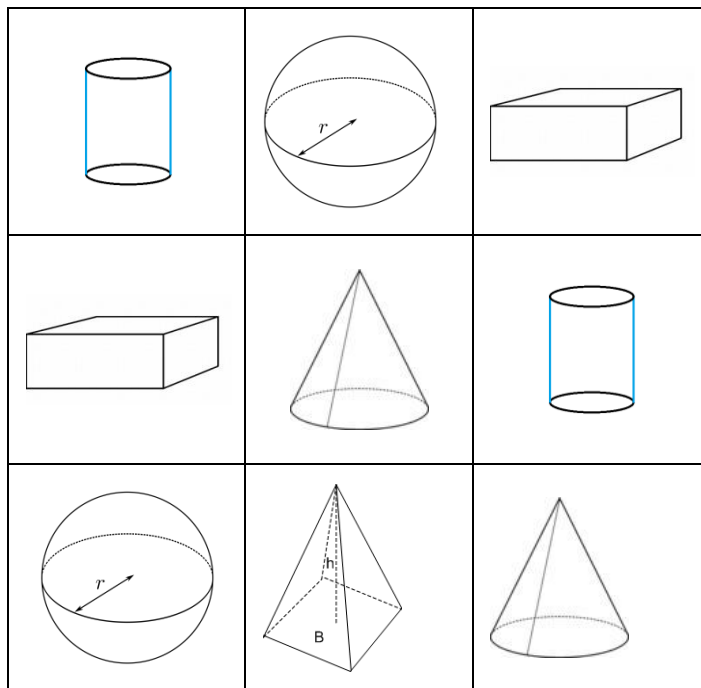



Erasmus+

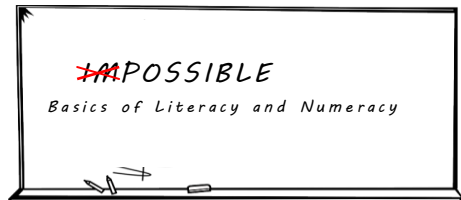

The project is funded by the European Commission

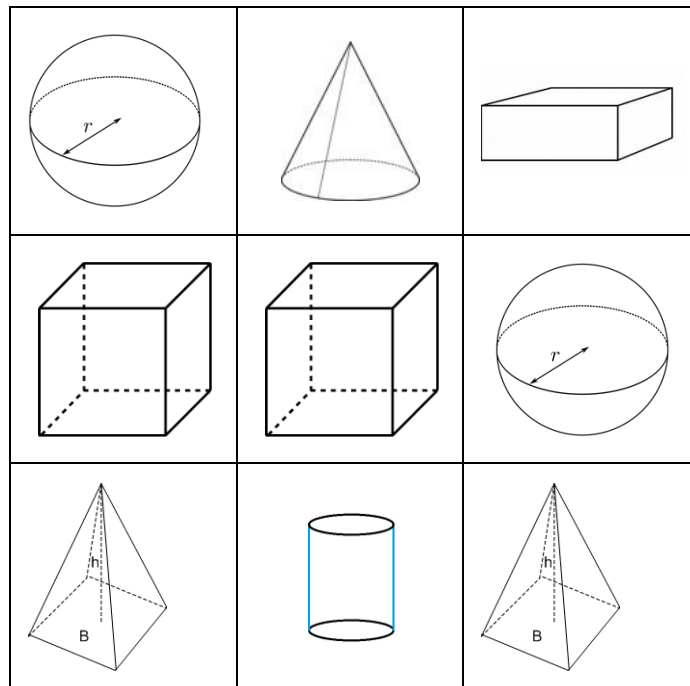
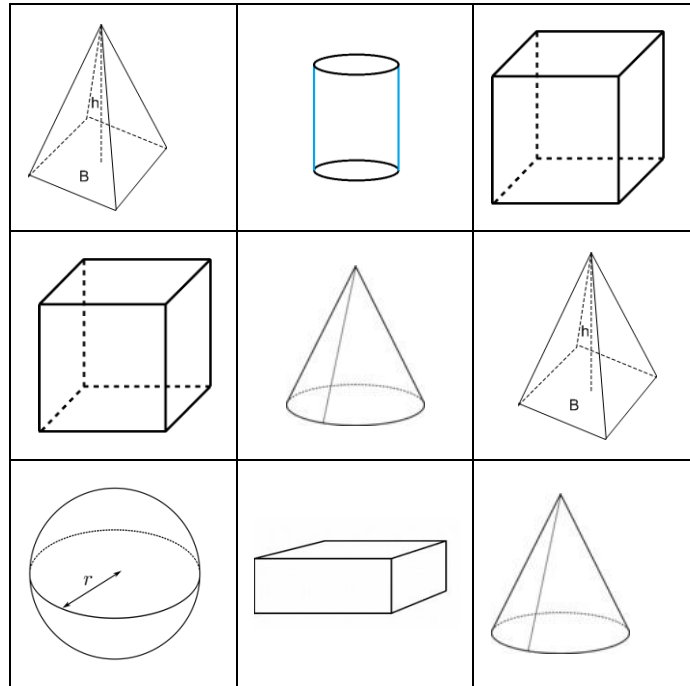

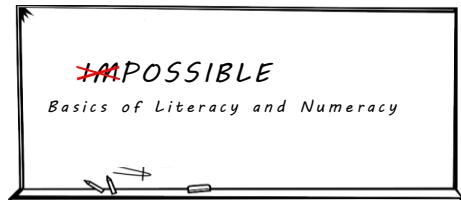

The project is funded by the European Commission

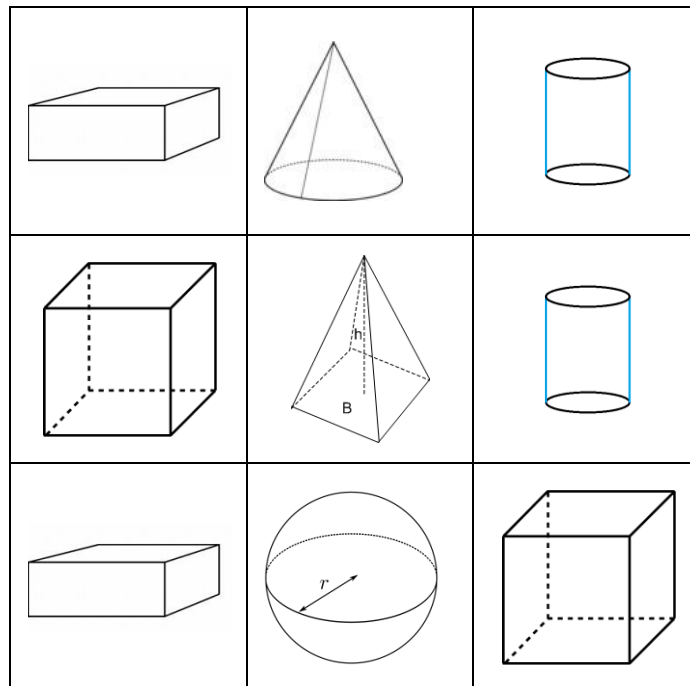
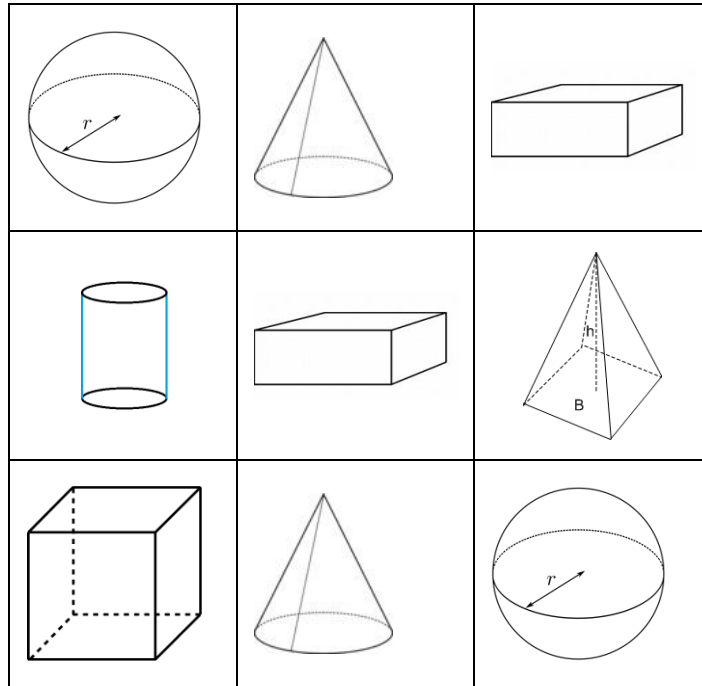



Erasmus+

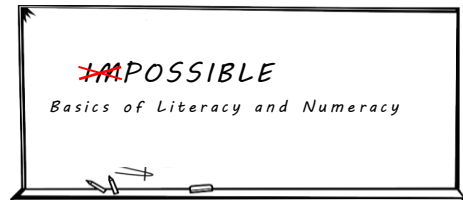

The project is funded by the European Commission

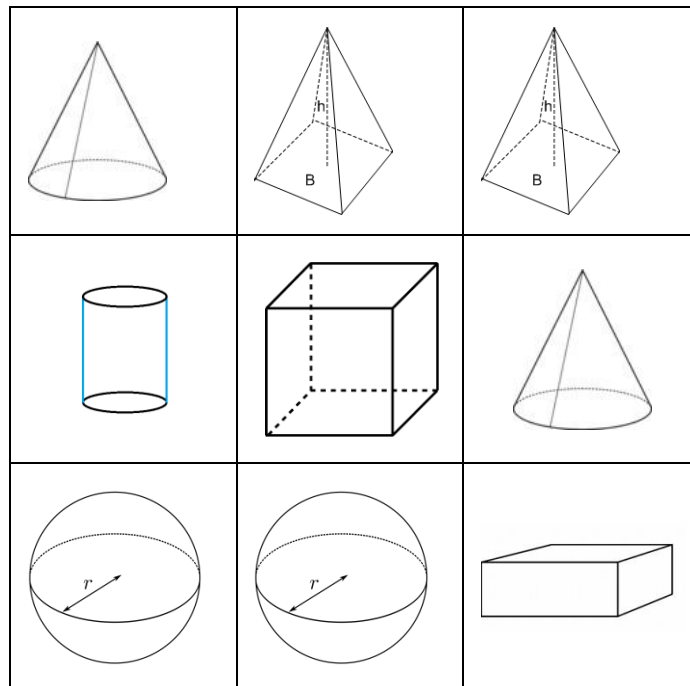
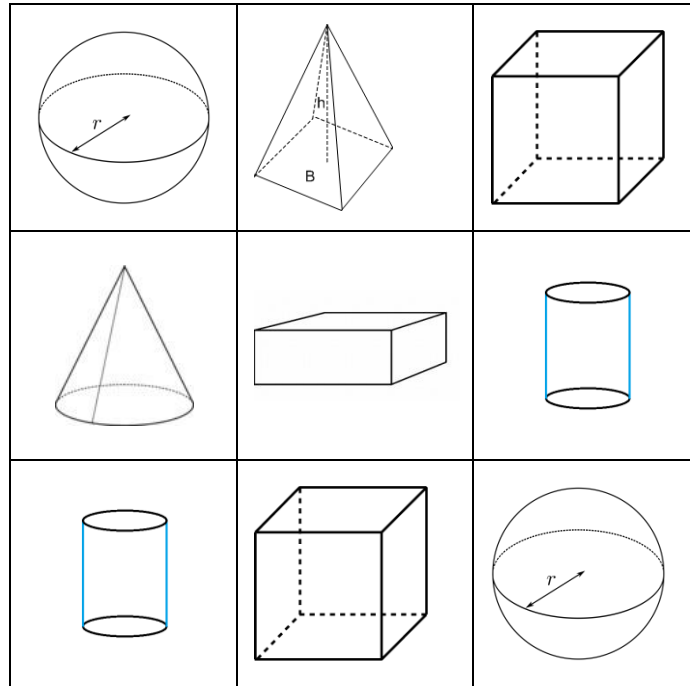



Erasmus+

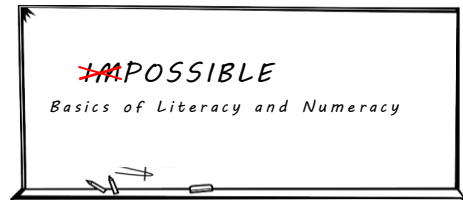

The project is funded by the European Commission

